

Tolleranze generali

Particolari stampati in materiale termoplastico: rif ISO 2768MK - Particolari lavorati alle macchine utensili: rif. UNI EN 22768
 Particolari tranciati in metallo: rif. UNI EN 22768 - grado IT10 per dim. lineari - grado IT11 quote di piega - angoli di piega ± 1

SCALA 1:1

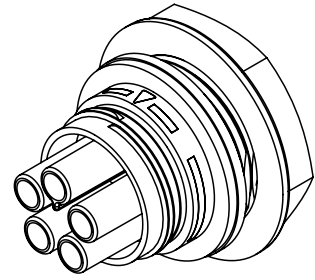
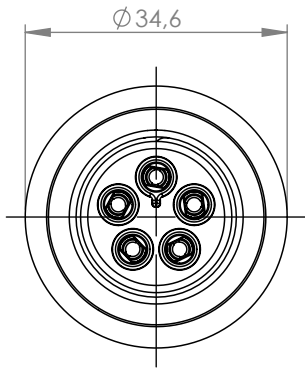

SEZIONE A-A

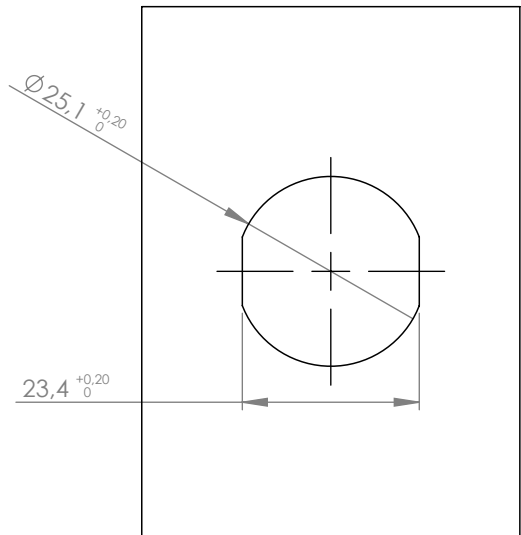
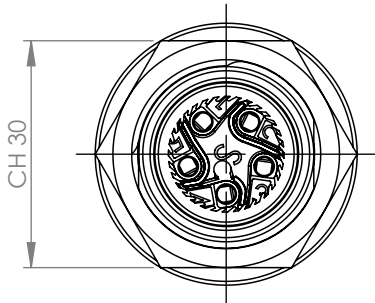
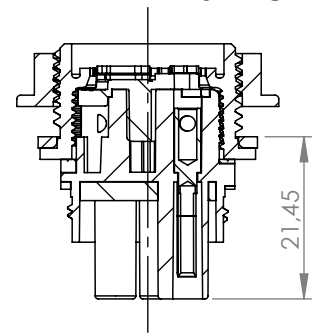
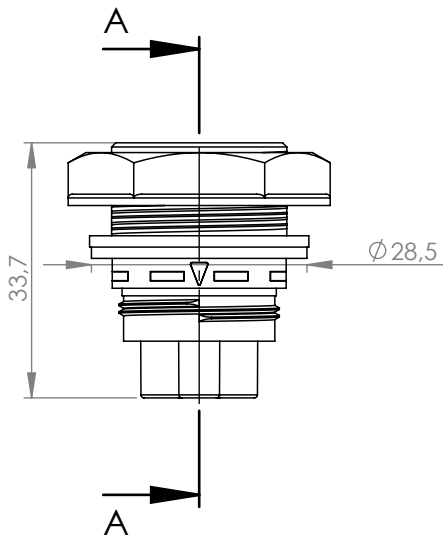

A meno di legge, si riserva la proprietà di questo documento con diritto di recesso. È vietata espressamente la ristampa o l'uso non autorizzato, in tutto o in parte, senza permesso scritto dalla Techno S.p.A.

Materiale-Material:

Trattamento-Treatment:

N° documento cliente
 Customer ref

Peso [gr]: 18.76
 Weight [gr]:

Disegnato - Drawn by: G.Flores

Data: 2023-09-11

Scala-Scale: 1:1

Controllato-Checked by:

Data:

Formato - Format A4

Titolo-Title:

Mini-Connect Socket Panel 5P M25
 Screw IP68 Nut

Progetto-Project:

TH387

N° Disegno - Drawing N°
 THB.387.F5A

Nome file - Filename
 THB.387.F5A

Rev.
 Rev.

Foglio N°
 Sheet N°

N° Fogli
 N° of sheets

