

4

3

2

1

Tolleranze generali

Particolari stampati in materiale termoplastico: rif ISO 2768MK - Particolari lavorati alle macchine utensili: rif. UNI EN 22768
Particolari tranciati in metallo: rif. UNI EN 22768 - grado IT10 per dim. lineari - grado IT11 quote di piega - angoli di piega ± 1

Num. articolo	NO_DISEGNO	TITOLO_1	Quantità
1	6000670KC	Corpo 4P Molla Wago x TH400U V0GFBlack	1
2	6000669KC	Pastiglia 4P Molla Wago x TH400U V0GFBlack	1

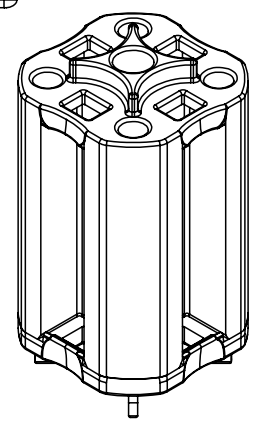
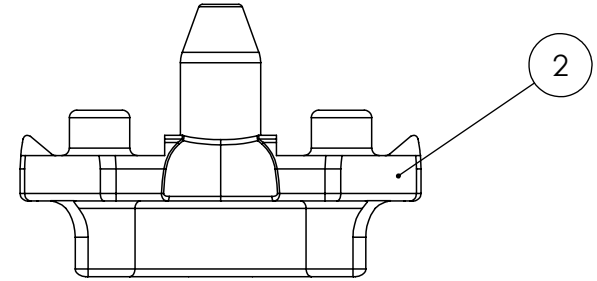
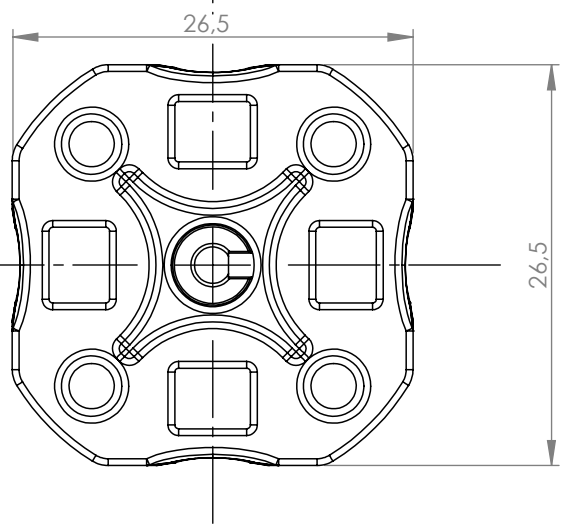
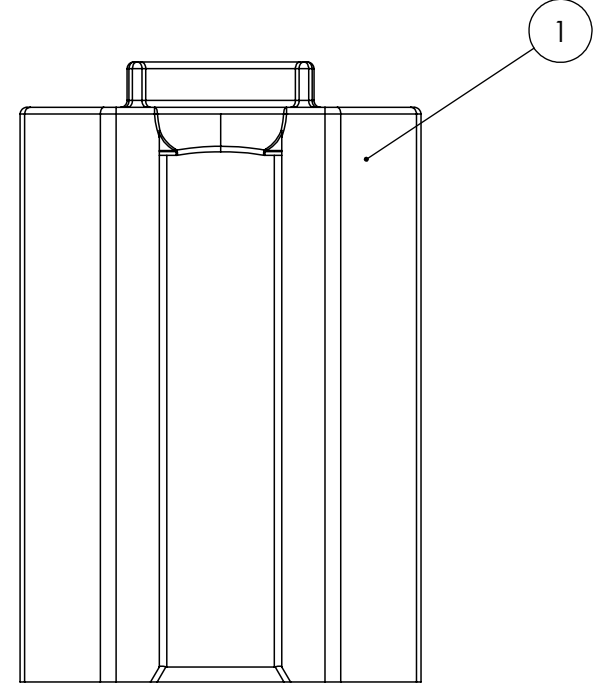
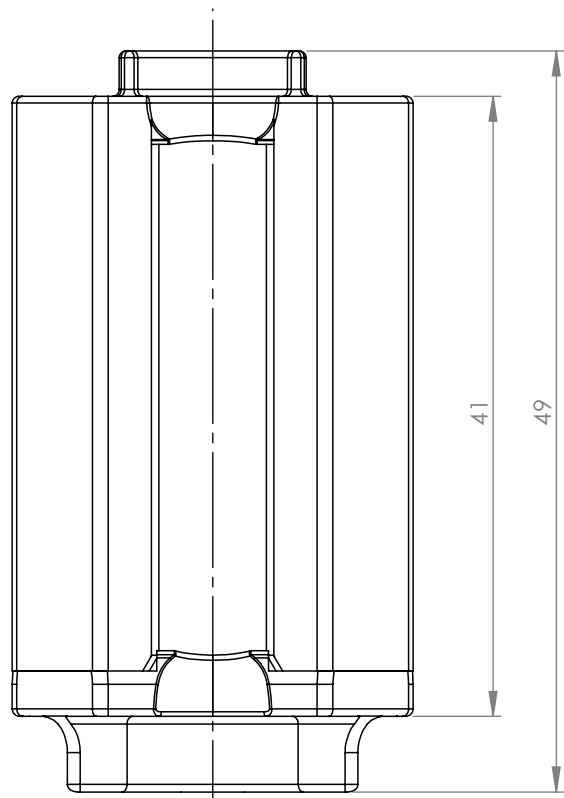

Materiale-Material:				Titolo-Title:			
Trattamento-Treatment:				Frutto 4P Molla Wago x TH400U V0GF-Black			
N° documento cliente		Peso [gr]:		N° Disegno - Drawing N°		Rev.	
Customer ref		Weight [gr]:		6DB077400		Foglio N°	
Disegnato - Drawn by: Marco Strada		Data: 2024-02-01		Scala-Scale: 1:1		Sheet N°	
Controllato - Checked by: M.Strada		Data: 2024-02-01		Formato - Format A4		N° Fogli	
						N° of sheets	

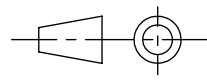

N° Disegno - Drawing N°		Rev.		Foglio N°		N° Fogli	
6DB077400		00		1		1	
Nome file - Filename							
6DB0774							

4

3

2

1