

*= Quota variabile per tipologia di cavo
Variable dimension by type of cable

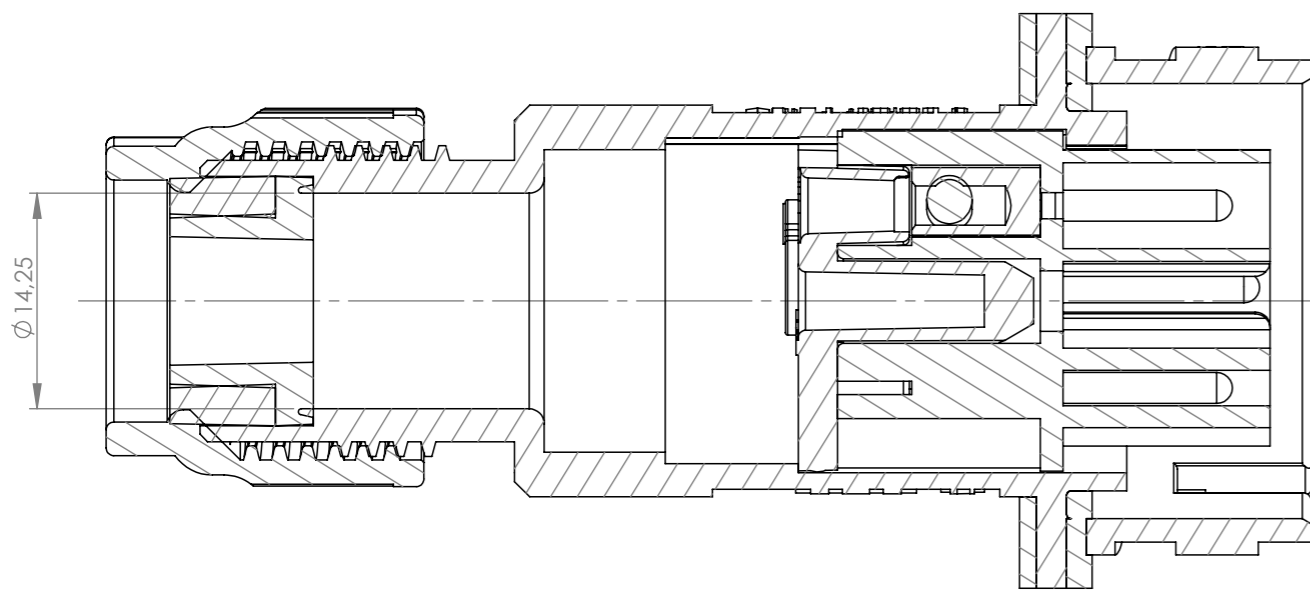

SEZIONE A-A
SCALA 2 : 1

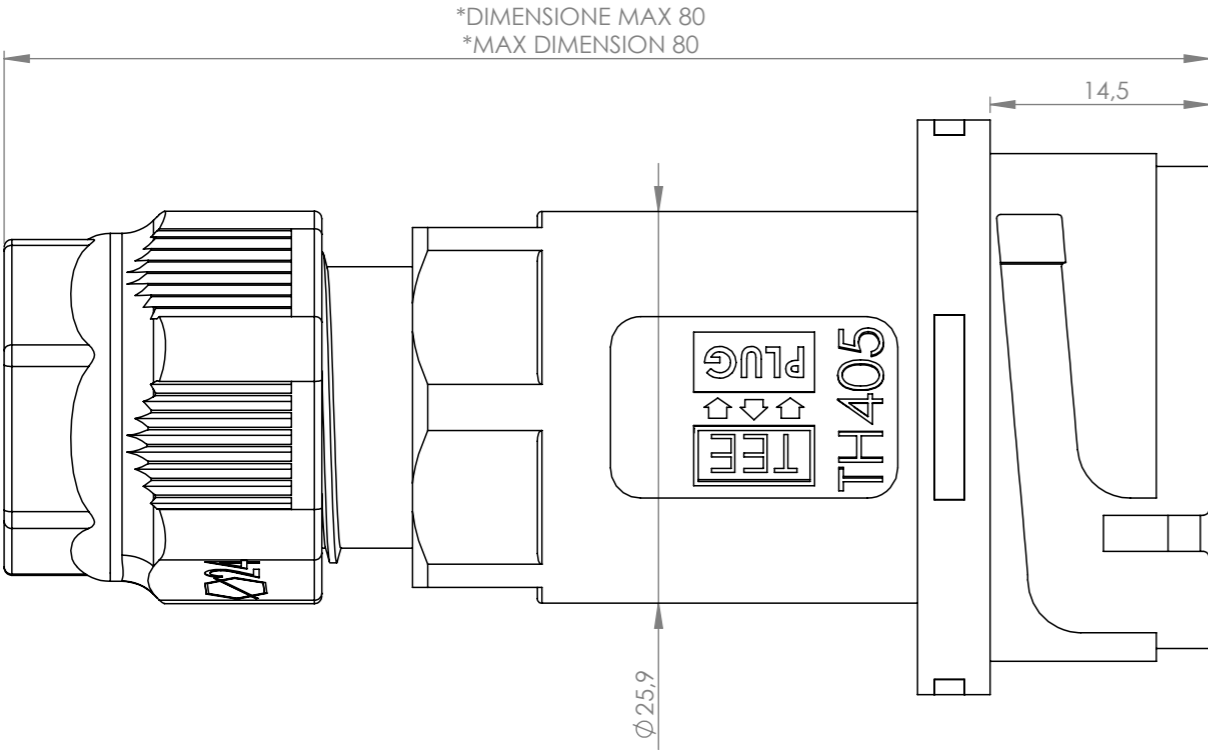
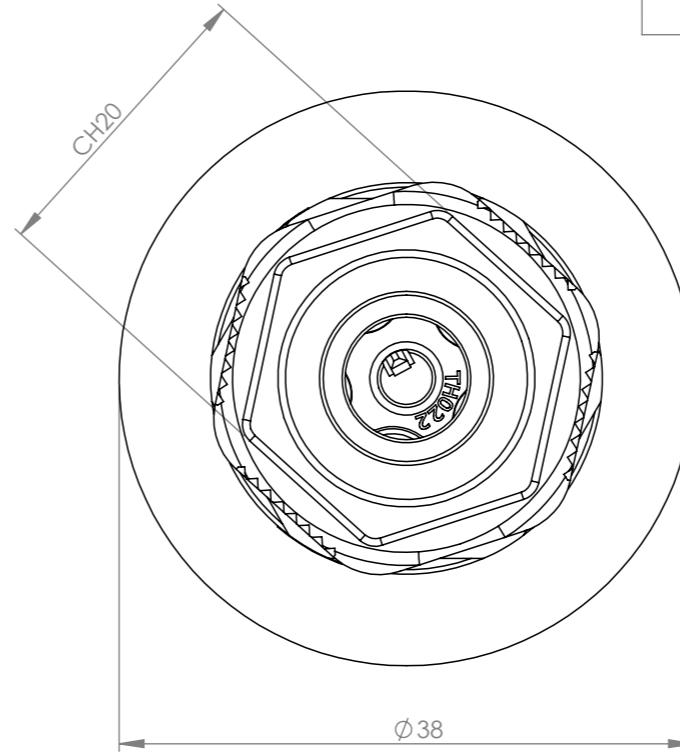

Tolleranze generali

Particolari stampati in materiale termoplastico: rif ISO 2768MK - Particolari lavorati alle macchine utensili: rif. UNI EN 22768
Particolari tranciati in metallo: rif. UNI EN 22768 - grado IT10 per dim. lineari - grado IT11 quote di piega - angoli di piega ± 1

ACCESSORI/ACCESSORIES

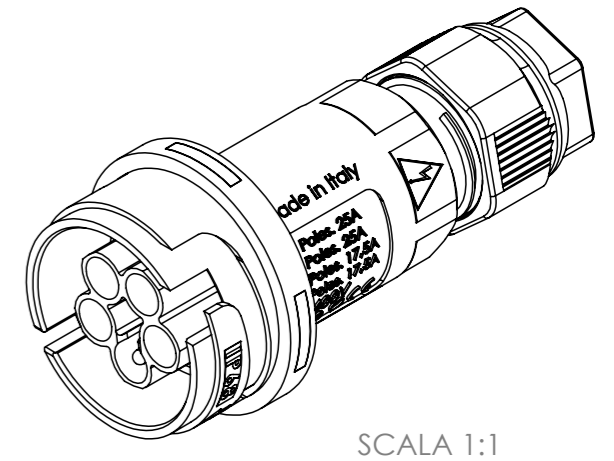
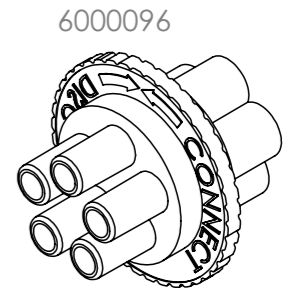
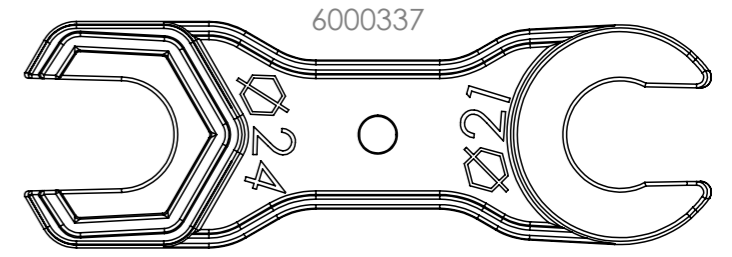

SCALA 1:1

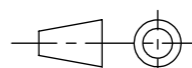
Questo disegno è proprietà esclusiva di Techno e non può essere copiato, ristampato, o comunque utilizzato senza autorizzazione scritta della Techno s.p.a. This drawing and all informations contained here can not be used or reproduced, integrally or partially, without Techno s.p.a. written authorization.	Materiale-Material:		Titolo-Title:	
	Trattamento-Treatment:		Connector Plug 5P Screw D7-14 IP68	
	N° documento cliente Customer ref	Peso [gr]: Weight [gr]:	Progetto-Project:	
	Disegnato - Drawn by: G.Flores	Date: 2023-02-10	Scala-Scale: 1:1	TH405
Controllato-Checked by: M.Strada	Date: 2023-07-31	Formato - Format A3	N° Disegno - Drawing N° THB.405.A2A	Rev. 00
				Foglio N° Sheet N° 1
				N° Fogli N° of sheets 1