

Tolleranze generali Particolari stampati in materiale termoplastico: rif ISO 2768MK - Particolari lavorati alle macchine utensili: rif. UNI EN 22768
 Particolari tranciati in metallo: rif. UNI EN 22768 - grado IT10 per dim. lineari - grado IT11 quote di piega - angoli di piega ± 1

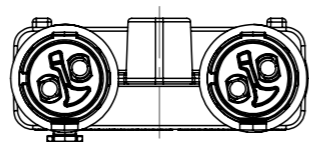
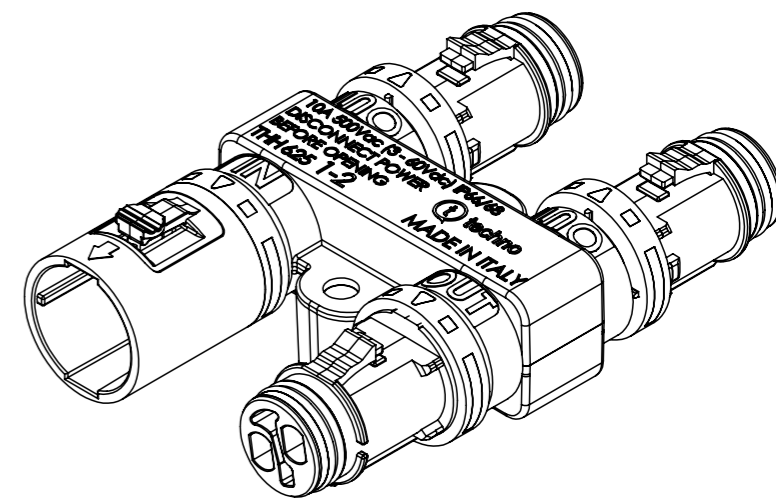
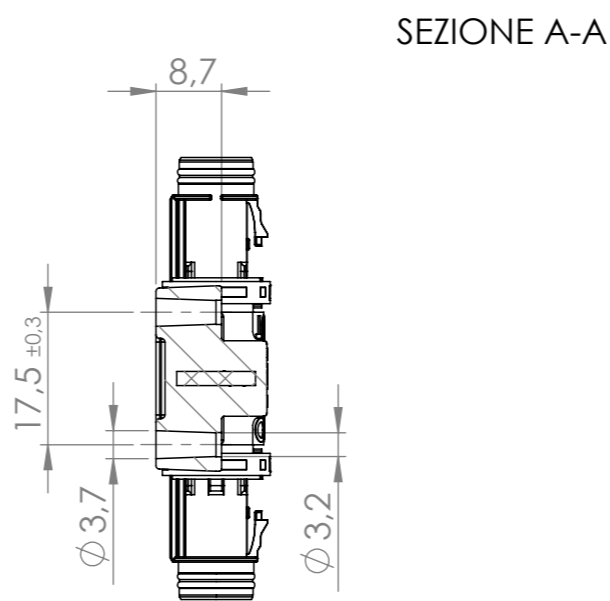
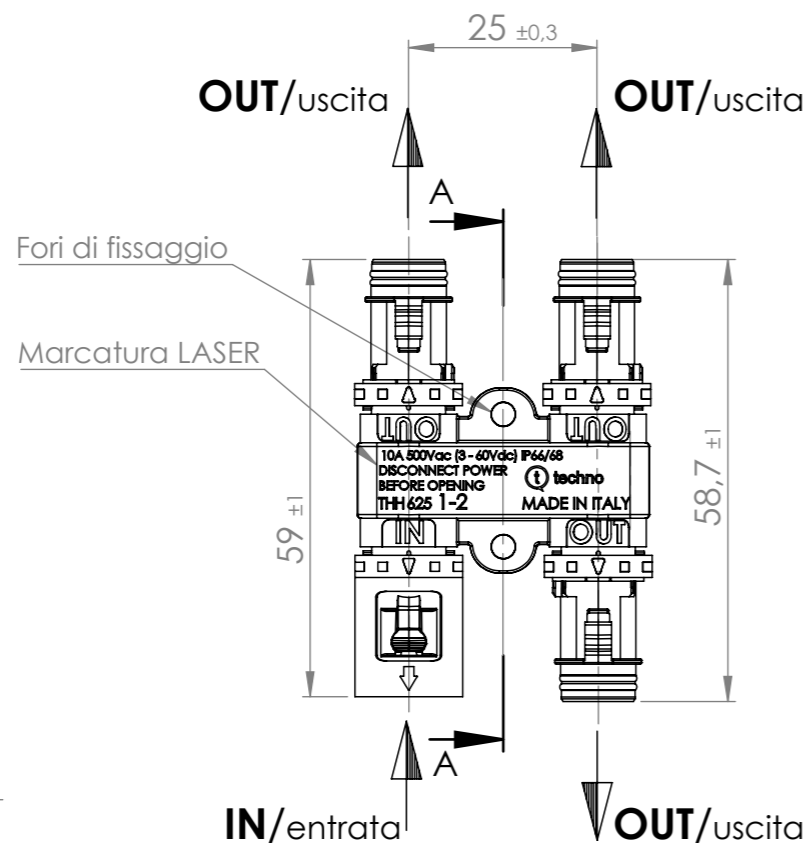
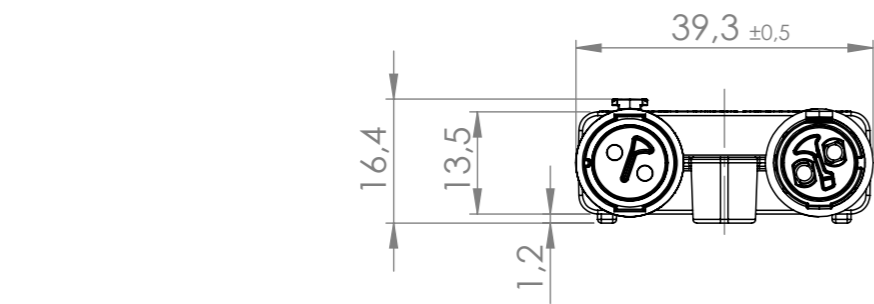

Questo disegno è proprietà esclusiva di Techno e non può essere riprodotto, modificato, copiato, distribuito, né in tutto né in parte, senza l'autorizzazione scritta della Techno. This drawing and all informations contained here can not be used or reproduced, modified, copied, distributed, neither in whole nor in part, without Techno written authorization.	Materiale-Material:		Titolo-Title:		
	Trattamento-Treatment:		Distributor 4ways 2P IP68 Basic		
	N° documento cliente Customer ref		Peso [gr]: Weight [gr]:	Progetto-Project:	
	Disegnato - Drawn by: S.Borgonovo		Date: 2019-05-27	TH625	
Controllato-Checked by: M.Strada		Date: 2023-04-13	Scala-Scale: 1:1	N° Disegno - Drawing N° THH.625.A2A	
				Nome file - Filename THH.625.A2A_12-02	
				Rev. 00	Foglio N° Sheet N° 1